

## Capacidade de Carga - Load Capacity - Capacidad de carga

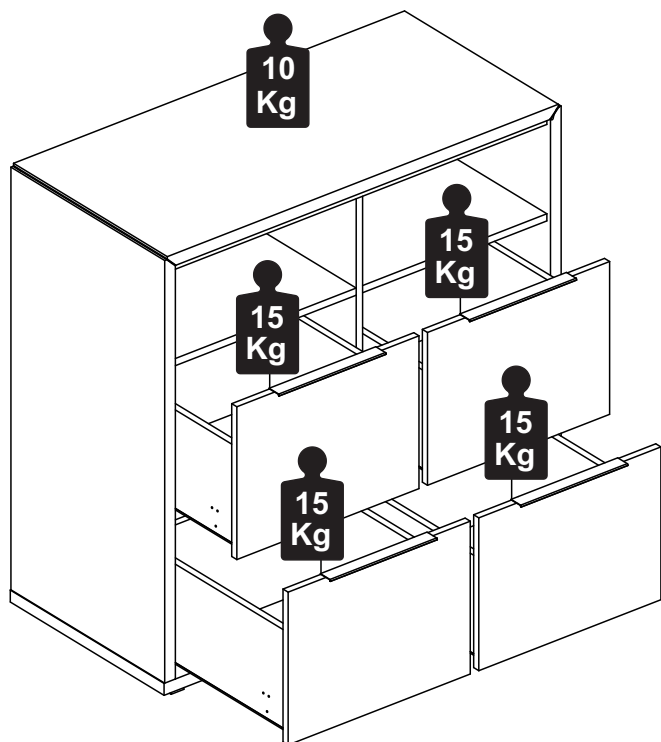

### Manutenção e Limpeza

Vidros: pano levemente umedecido com álcool, seguido de pano seco.  
Madeiras: pano levemente umedecido com água, seguido de pano seco.  
\*Nunca utilizar produtos químicos ou abrasivos.

### Maintenance and Cleaning

Glasses: cloth lightly moistened with alcohol, followed by dry cloth.  
Woods: cloth slightly moistened with water, followed by cloth seco.  
\*Never use chemicals or abrasives.

### Mantenimiento y Limpieza

Vidrios: legeramente humedecido con alcohol, seguido de un paño seco.  
Madera: ligeramente humedecido con agua, seguido de un paño seco.  
\*No utilice nunca productos químicos o abrasivos.

## INSTRUÇÕES DE MONTAGEM ASSEMBLY INSTRUCTIONS INSTRUCCIONES DE MONTAJE

### ARMÁRIO BAIXO 4 GAVETAS LOW CABINET 4 DRAWERS ARMARIO BAJO 4 CAJONES

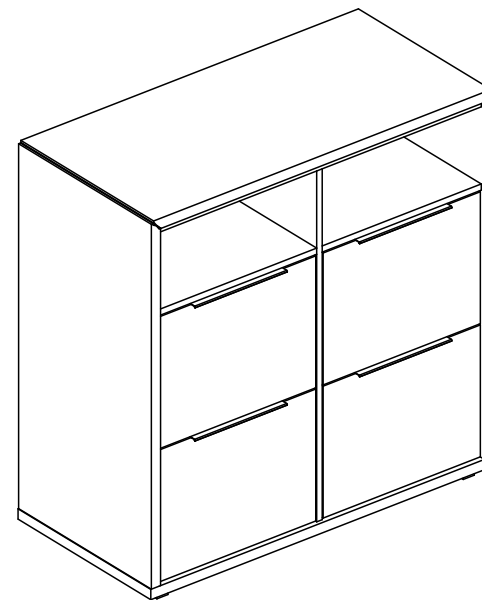

REF. #EDG9394

 **GEBB WORK**  
MOBILIÁRIO PARA ESCRITÓRIO

GEBB Work Ind. de Móveis Ltda.  
Rua Beatriz Dall'Onder, 120  
Distrito Industrial

95706-350 - Bento Gonçalves - RS - Brasil  
Fone: (0XX54) 3454-1105 Fax: (0XX54) 3453-1407  
Phone: (0XX54) 3454-1105 Fax: (0XX54) 3453-1407  
E-mail: [pedidos@gebbwork.com.br](mailto:pedidos@gebbwork.com.br)  
[www.gebbwork.com.br](http://www.gebbwork.com.br)

## LISTA DE PEÇAS

- 01 - Lateral Direita
- 02 - Lateral Esquerda
- 03 - Costa
- 04 - Tampo Intermediário
- 05 - Lateral Gaveta Esquerda
- 06 - Lateral Gaveta Direita
- 07 - Frente Gaveta
- 08 - Divisão
- 10 - Fundo Gaveta
- 11 - Base
- 12 - Prateleira Fixa
- 13 - Tampo
- 14 - Costa Gaveta

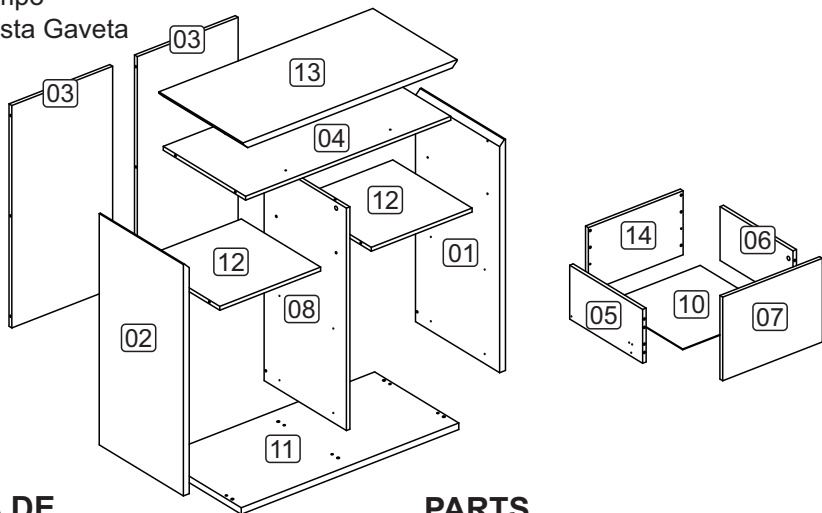

## LISTA DE PIEZAS

- 01 - Lateral Derecha
- 02 - Lateral Izquierda
- 03 - Revés
- 04 - Tablero Intermedio
- 05 - Lateral Cajón Izquierda
- 06 - Lateral Cajón Derecha
- 07 - Frente Cajón
- 08 - Travesía Manija
- 10 - Revés Cajón
- 11 - Base
- 12 - Repisa Fija
- 13 - Tapa
- 14 - Revés Cajón

## PARTS IDENTIFICATION

- 01 - Right Side
- 02 - Left Side
- 03 - Back
- 04 - Intermediate Surface
- 05 - Left Drawer Side
- 06 - Right Drawer Side
- 07 - Drawer Front
- 08 - Handle Traverse
- 10 - Drawer Back
- 11 - Base
- 12 - Fixed Shelf
- 13 - Top
- 14 - Drawer Back

(4x)

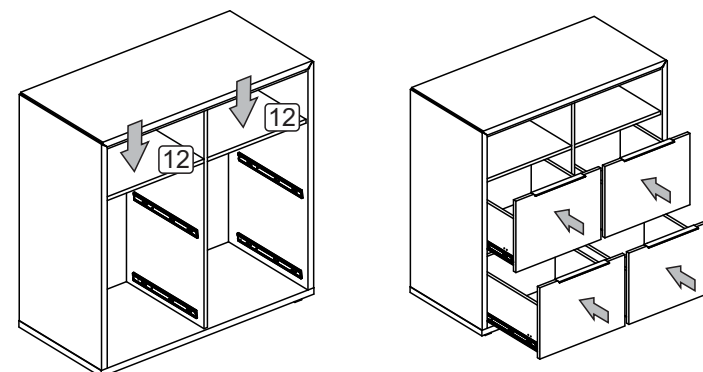
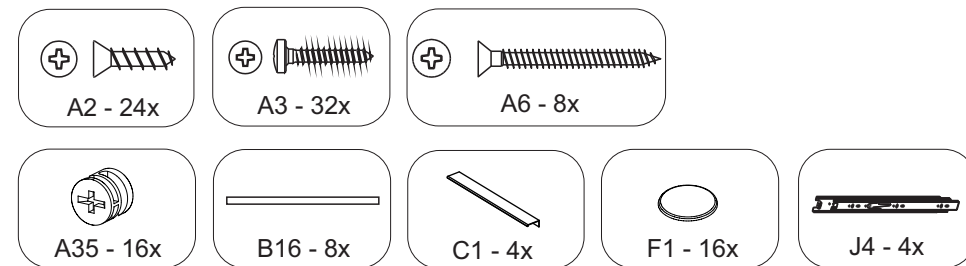
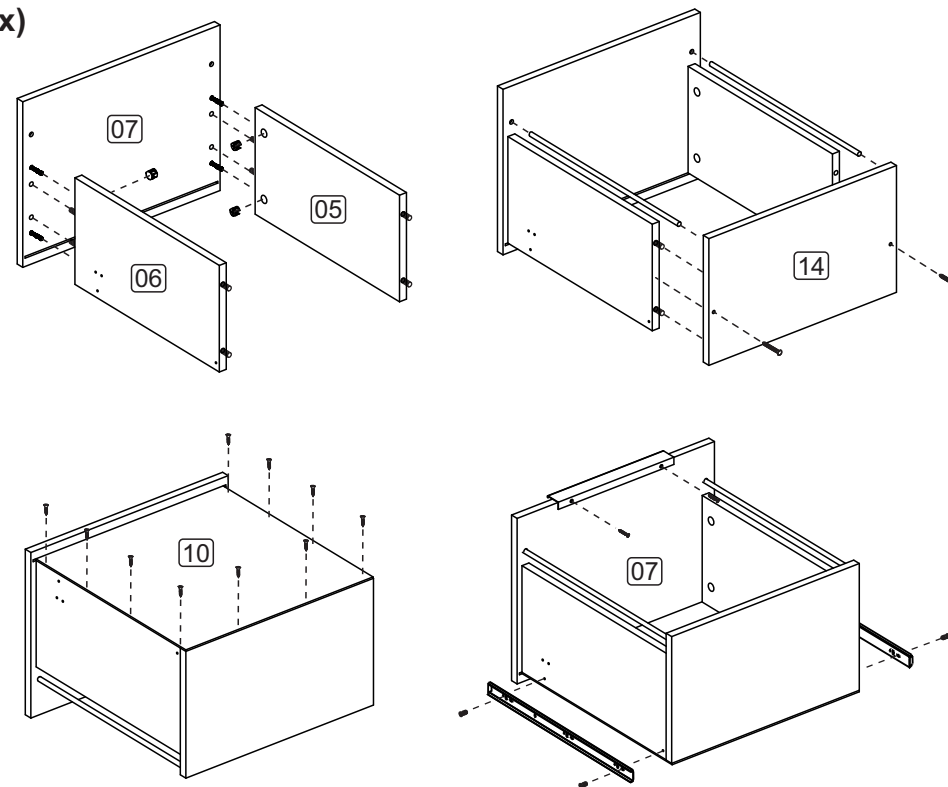

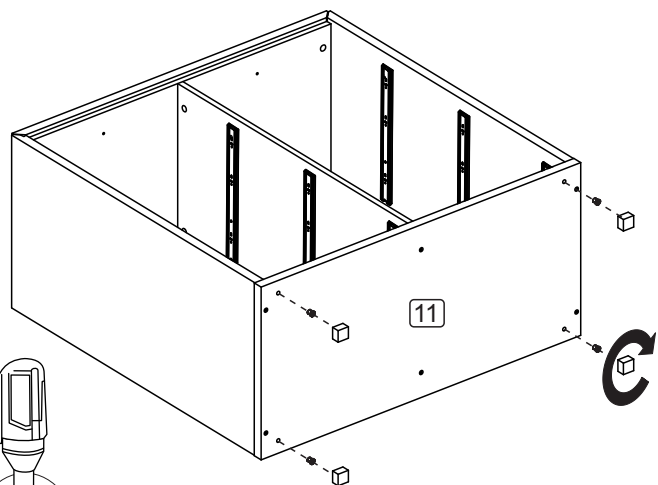
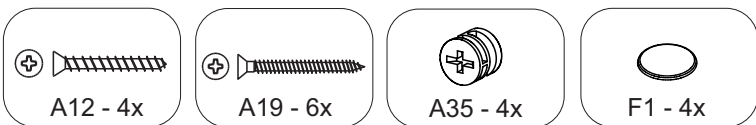
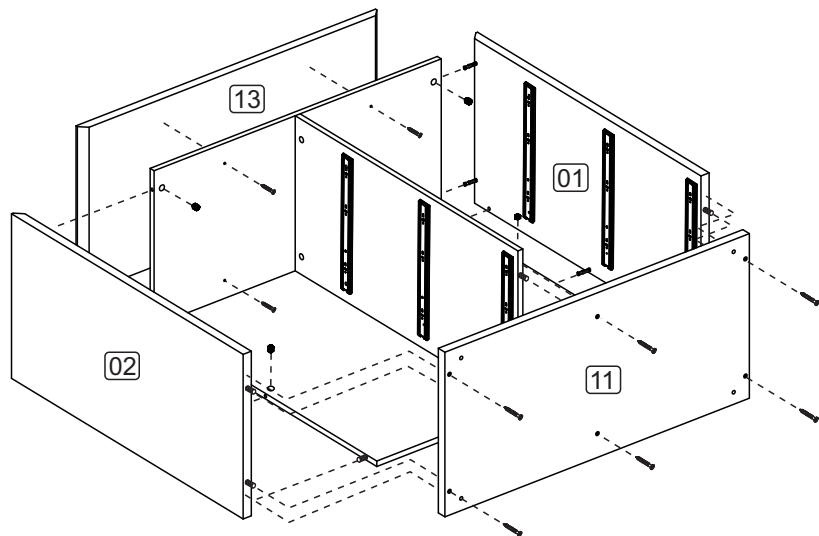

Usar ponteira de parafusadeira sextavada

A36



# ACESSÓRIOS ACCESSORIES ACCESORIOS

A2 - PARAF. 3,5x14 CC  
**60x**



A3 - PARAF. 3,5x20 CP  
**32x**



A6 - PARAF. 3,5x40 CC  
**8x**



A12 - PARAF. 4,0x30 CC  
**4x**



A19 - PARAF. 4,5x50 CC  
**6x**



A32 - PARAF. MINIFIX  
**24x**

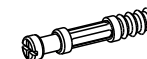

A33 - PARAF. MINIFIX DP  
P/15mm **1x**



A35 - TAMBOR  
MINIFIX **26x**



A36 - BUCHA M6x13  
**4x**



A40 - HASTE VB  
**8x**



A41 - TAMBOR VB  
**8x**



B17 - HASTE MET.  
406mm **8x**



C1 - PUXADOR ALUMÍNIO  
**4x**



D1 - CAVILHA 8x30  
**44x**

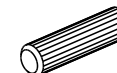

D3 - CAVILHA 8x50  
**2x**

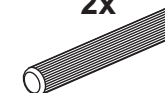

F1 - TAPA FURO  $\varnothing$ 18  
**20x**



H8 - PERFIL ACABAM.  
ALUMÍNIO **2x**

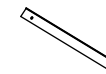

J4 - CORREDIÇA  
TELESC. 400mm **4x**



L7 - SAPATA EM ALUMÍNIO  
30x30x20mm **4x**



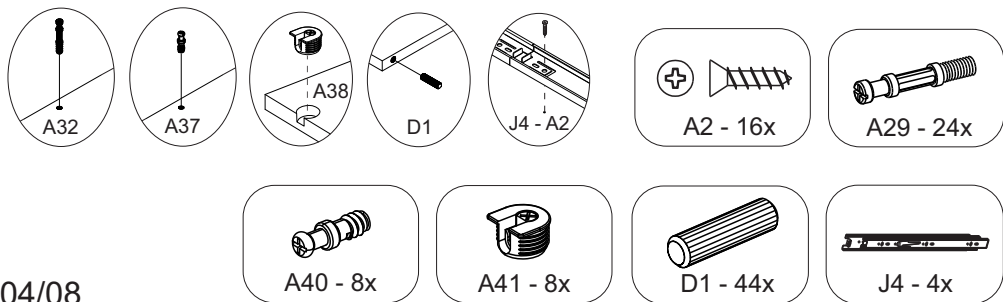
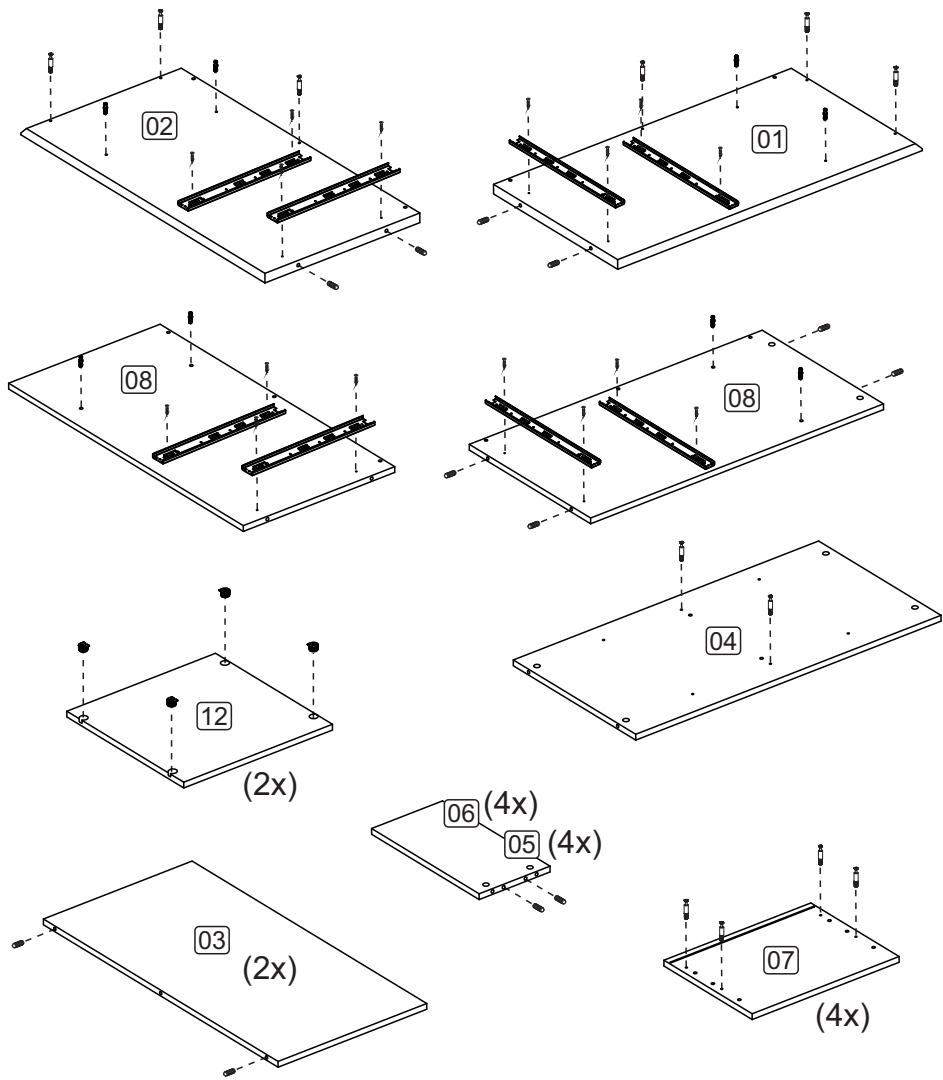

04/08

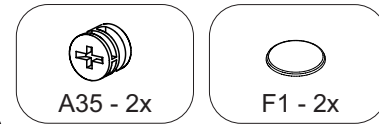
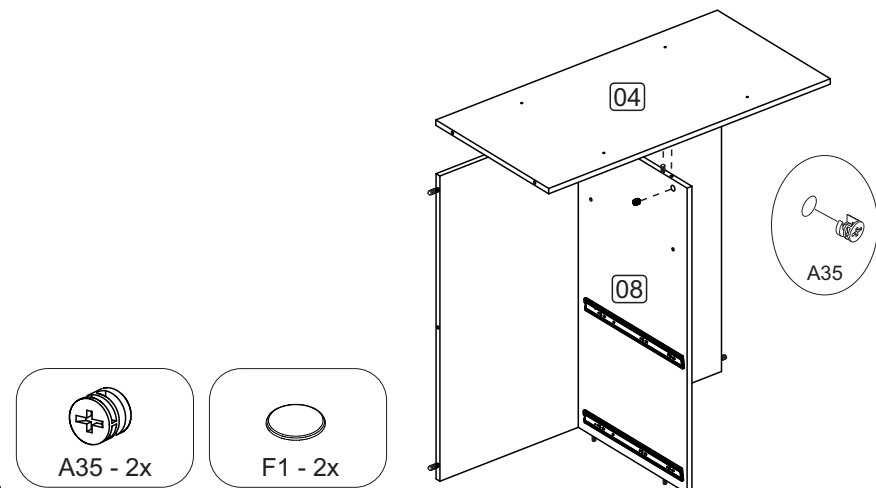
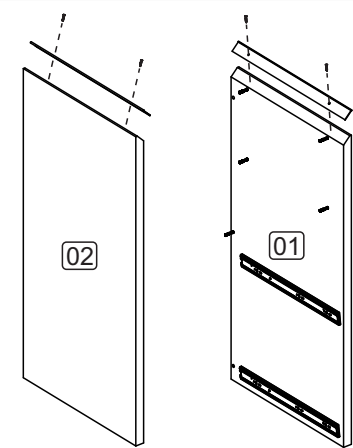
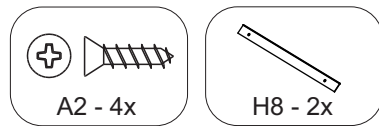
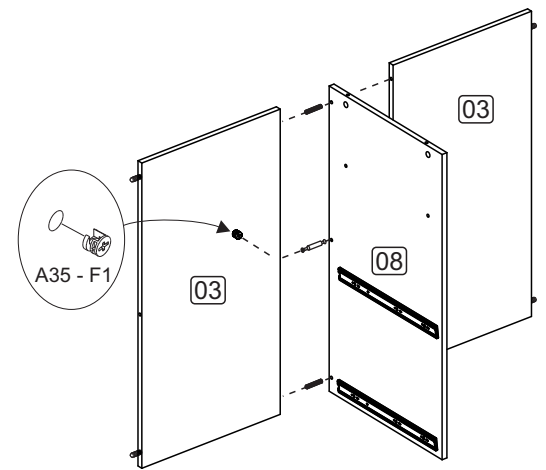
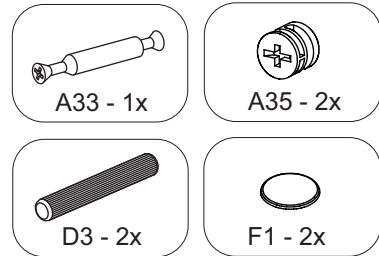

05/08